

SERPAC C-28

Electronics Enclosures

NOTES:
1. WHEN MACHINE OR I PLATES MODIFICATIONS ARE REQUIRED,
USE THE CENTER OF THE ENCLOSURE TO DIMENSION.

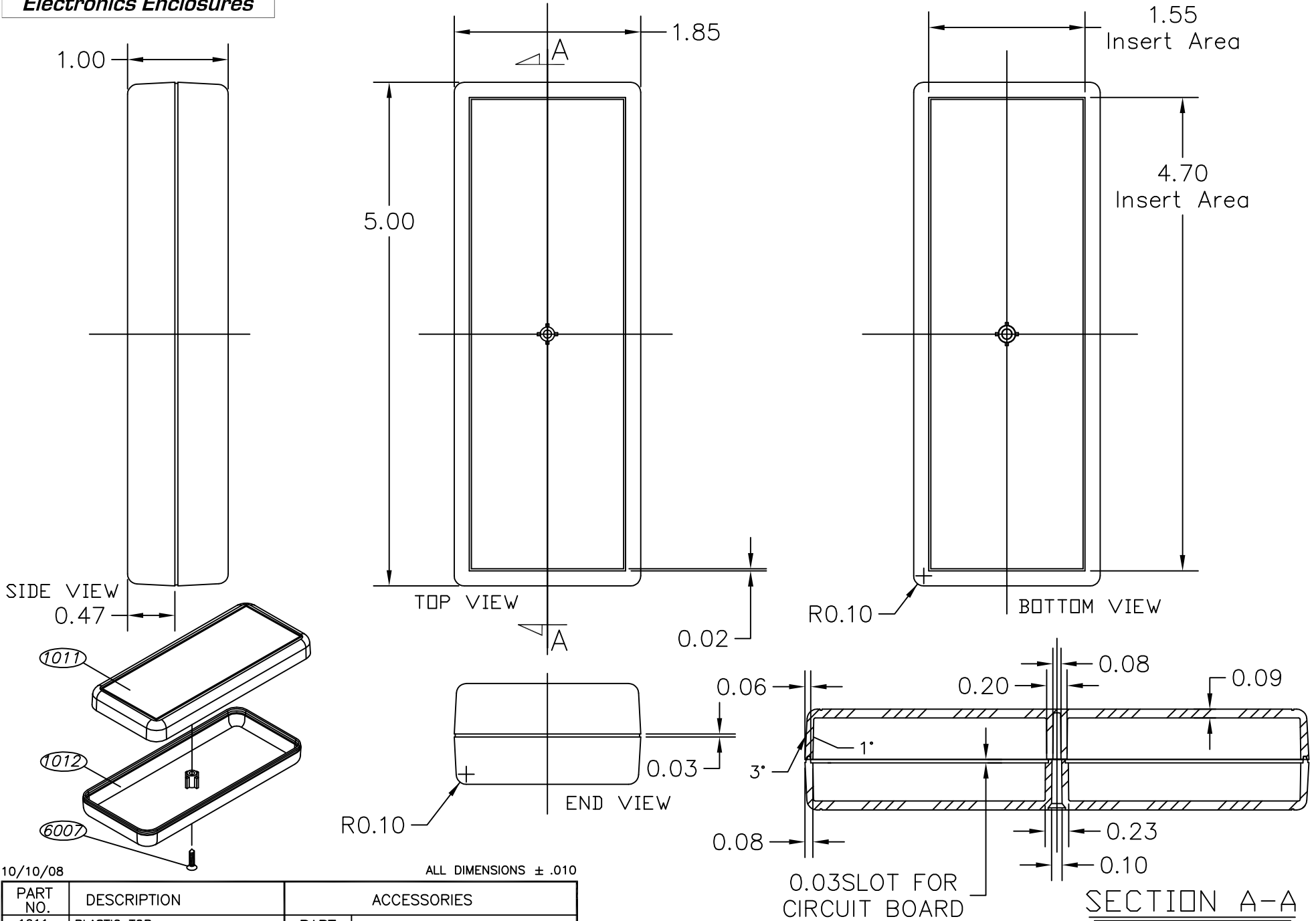

10/10/08

ALL DIMENSIONS ± .010

PART NO.	DESCRIPTION	ACCESSORIES	
1011	PLASTIC TOP	PART NO.	DESCRIPTION
1012	PLASTIC BOTTOM	55	KEY HOLDER
6007	SCREW	1030	POCKET CLIP